

REVISIONS

REV.	DESCRIPTION	DATE	APPROVED
------	-------------	------	----------

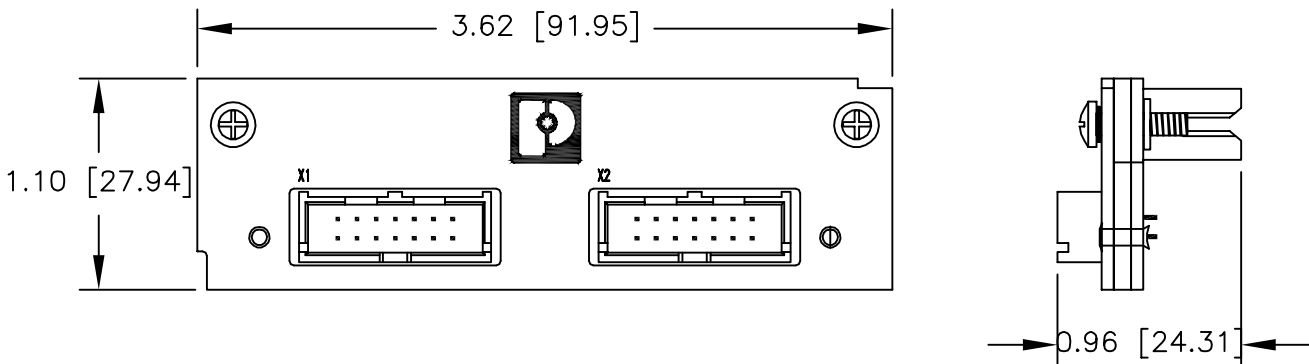
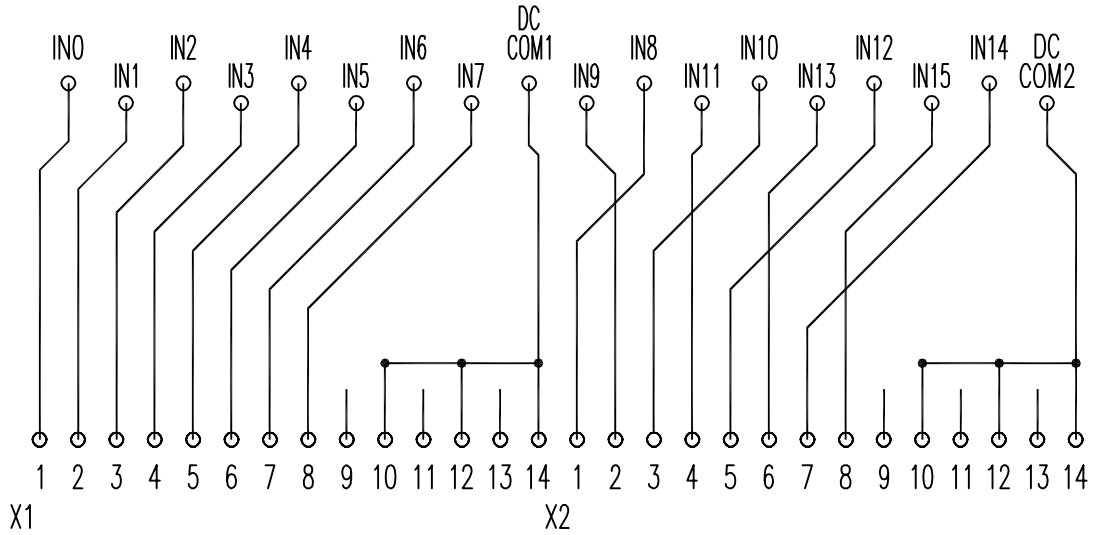

UNLESS OTHERWISE SPECIFIED
DIMENSIONS ARE IN INCHES

PROJECTION TOLERANCES ANGLES
 ◎ □ .XX = ±.01 ±0.5°
 .XXX = ±.005

MATERIAL

FINISH

DO NOT SCALE PRINT

APPROVALS

DRAWN

CHECKED

APPROVED

DATE



P.O. BOX 4100
HARRISBURG, PA
(717) 944-1300
FAX (717) 944-1625

TITLE

FLKM14-PA-AB/
1769/IN

PDF

SIZE

A

DWG. NO.

2302450

REV.

0

SCALE N/A

SHEET 1/1